



POP portable projection screen on tripod

Description 2x3 Art. No: **ETP**

Characteristics: Most popular tripod screen. Strong top fixing. Matt white fabric. Foldable stand. Special locking for transport.

Accessories: assembly elements.

Warranty: 2 years.

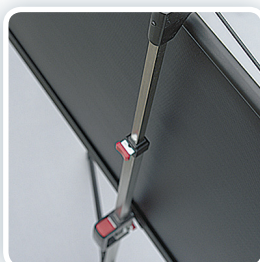
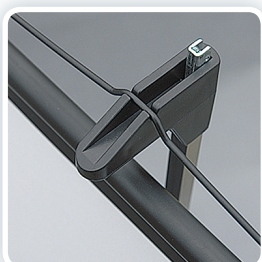

POP portable projection screen on tripod				
Format 4:3				
2x3 Art. No		ETP1014/43	ETP1216/43	ETP1419/43
Dimensions [cm]	total	153×114	171×128	203×153
	workspace A×B	147×108	165×122	195×145
Diagonal C [cm] (cal)		190 (75")	214 (84")	254 (100")
Black border [cm]		3		4
Side view [cm]		7×7		
Surface		PCV (Matt White)		
Weight [kg]		8,0	10,0	13,0
Warranty		2 years		
Parameters of the surface	Brightness scale	1,0-1,2 (DIN 19045)		
	Thickness [mm]	0,35		
	Front side	Matt White		
	Back side	black		
	Gain factor	1,0		
	Viewing angle	150°		

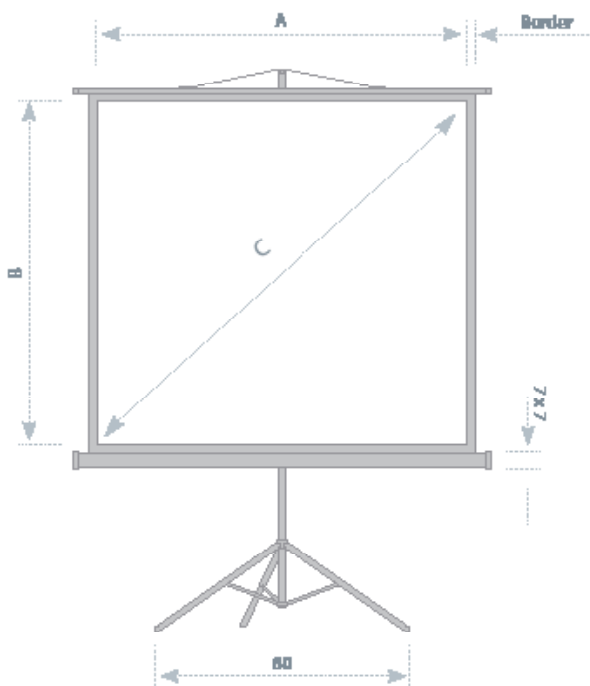
2x3 S.A.

73-231 Krzęcin, ul. Słoneczna 3, Polska

[i]: 801 23 00 23

[t]: +48 95 765 3848 [f]: +48 95 765 3850

[e]: info@2x3.pl [w]: www.2x3.eu



innovations in visual communication