

# interactive whiteboards



**2X3**  
AV Solutions

**esprit** plus  
by 2x3

**NEW**  
2012



- 1** interactive whiteboard
- 2** drywipe whiteboard
- 3** magnetic whiteboard

**esprit** plus  
by 2x3

2x3 esprit plus interactive board	
2x3 Art. No.	TIWEP
Total area (width × height)	177 × 129 cm
Usable area (width × height)	166 × 117 cm
Diagonal	80" (203,2 cm)
Depth	3,9 cm
Surface material	ceramic steel
Surface features	dry erase, magnetic
Weight	23 kg (50,7 lbs)
Technology	IR (infrared)
Operation mode	pointer, finger
Power consumption	0,5 W
Recommended Computer Parameters	Microsoft Windows Pentium CPU 512 MB RAM XP/Vista®/7 USB port
On the board	12 buttons activating preconfigured functions
Connection to the computer	USB
Warranty	2 years for hardware and software

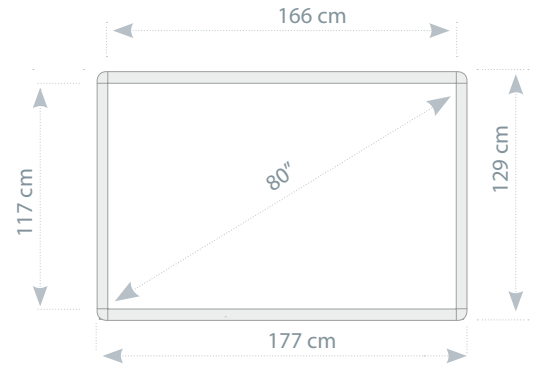

Surface carries **lifetime warranty!**

It is durable and resistant to scratching, dirt and even spray paint.

## Interactive presentation

Once the esprit plus board is connected to the computer which generates the image projected on the board, you can control the computer in an interactive way only manipulating the esprit plus board. You control it with any pointer, even your finger.



**Note!**

esprit plus is also available in kits with mobile stands and multimedia projectors.